

The SERIES 200 column cover system is ideal for those applications where economy of installation is a factor. Easy to install and field finish, the SERIES 200 can be used to enclose any structural column or condition where later access is not required. As well as being economical and easy to install, the covers provide a permanent and durable decorative feature to office environment or corridor. This column cover can be mounted in either interior or exterior conditions, with customer provided subframing. (Use of weather proof joint compound required for exterior use.)

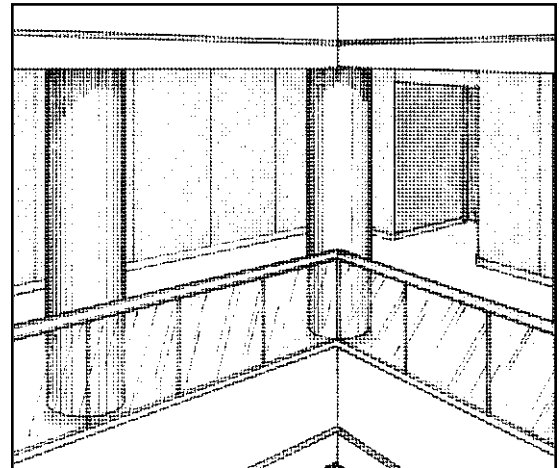

The SERIES 200 column cover used to enclose structural columns at the edge of an atrium balcony. This adds a decorative feature to the area instead of just acting as concealment.

The SERIES 200 column cover system features a field finished seamless joint similar to the SERIES 100 column covers, but at half the cost. Roll-formed from 16ga Galvaneal steel, and supplied in two identical halves, the SERIES 200 is a superior alternative to GFRG. The field installer simply provides two standard metal drywall studs, and common sheet metal screws to install the covers. Standard drywall joint compound techniques produce a monolithic appearance ideal for field applied paint or wall coverings. These column covers are supplied with a paint ready finish. Sizes available range from a minimum of 12" in diameter (304.8 mm), up to 30" in diameter (762 mm), with a single length height up to 12' (3.658 M). (Note: Use minimum of 16" diameter (406.4 mm) for column covers greater than 12' in height.) Larger diameters are also available in alternate materials, so check the factory for your particular requirements. As a standard, the SERIES 200 is manufactured using 16ga .062" (1.6 mm) electrogalvanized steel.

Series 200 Details & Installation

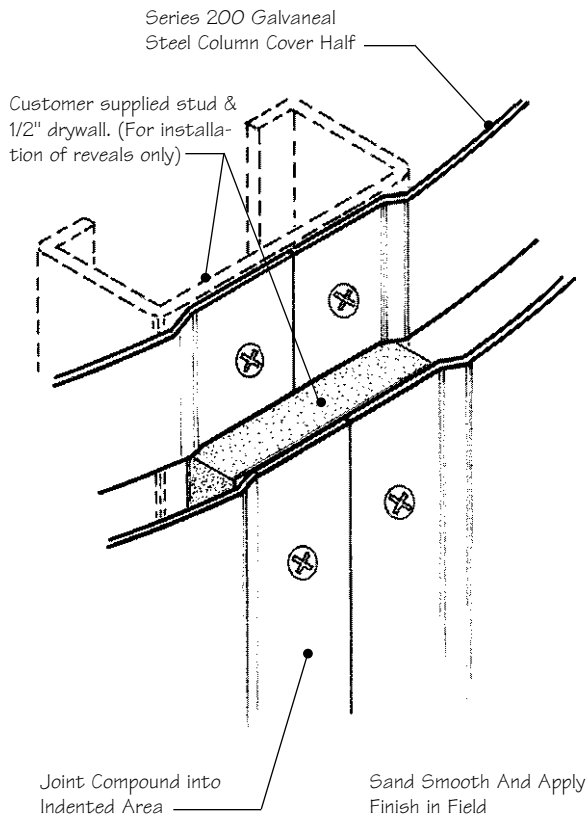

Installation Details

No Scale

The SERIES 200 column cover system consists of the following parts:

- 1) Two custom roll-formed column cover halves.
- 2) One set of drawings / instructions.

The following customer supplied parts are also required for proper installation:

- 1) Two 2-1/2" metal or wood studs.
- 2) Angle brackets or runner channel for securing studs to floor and ceiling
- 3) Plumb bob & carpenters level.
- 4) 1/8" or similar size drill bit.
- 5) #8 flat head phillip's sheet metal screws (for securing column cover halves to metal studs).
- 6) Two 1/2" thick gypsum board strips 2" wide (optional).
- 7) Denatured alcohol for final cleaning prior to finishing.

The proper positioning and anchoring of the metal studs is the single most important aspect of installing the SERIES 200 column cover. The studs must be plumb and properly spaced from one another, and the mounting brackets securely fastened to the floor and ceiling in order for the column cover halves to properly install. For specific installation instructions, please refer to the detailed installation instructions below, or in case of further questions, consult the factory.

Typical installation procedure

- 1) Determine the position of the column cover around whatever structural member you wish to enclose, and then install one stud in place, using a plumb bob and level to ensure plumb-ness. Using a tape measure, position the opposite stud in place so that the two studs are 1" closer together than the diameter of the column cover halves. Make sure that studs are securely fastened to the ceiling and floor utilizing proper fasteners.
- 2) Using 1/2" drywall, cut two 2" wide strips the same length as the column cover posts and tape the strips to the outside face of the studs. Position both column covers so that their adjoining fins butt together, centered on the studs. Fasten to the studs with #8 flat head self tapping screws spaced no more than 6" apart.
- 3) Clean with alcohol any accumulated oil, grease or dirt.
- 4) Trowel on reinforced joint compound and embed reinforced tape at joint.
- 5) Apply skim coat and sand smooth.
- 6) Repeat step three and then apply field finish.

SAMPLE SPECIFICATION

Section 05600 Architectural Metal Column Covers

Part 1 - General

1.01 Description of work

A. Furnish all material necessary for a complete installation of the SERIES 200 column covers, exclusive of field applied material (i.e. joint compound, substructure, etc.).

1.02 Submittals

A. Submit complete shop drawings detailing quantities, sizes, finish, configurations, and column attachment methods.
B. Submit product literature, specifications, information, and installation instructions.

1.03 Quality Assurance

A. Manufacturer to have a minimum of ten years experience in the manufacturing of column covers.
B. Manufacturer to inspect all aspects of the product to ensure that specifications have been met, and that they comply with approved shop drawings.
C. Manufacturer shall issue a one year limited warranty ensuring product against defects in workmanship and materials.

Part 2 - Products

2.01 Acceptable Manufacturers

Pittcon Industries
6409 Rhode Island Ave.
Riverdale, MD 20737

Pittcon Industries
3330 W. Flower Street
Phoenix, Arizona 85017

2.02 Materials

A. Column covers shall be roll-formed from 16ga Galvaneal steel with paint ready finish to match architects sample.
B. All fasteners are to be concealed.
C. All column covers are to be shipped with protective material on all exposed surfaces.

2.03 Fabrication

A. Column covers shall be roll-formed to specific dimensions and tolerances, and accurately formed to radii shown on drawings.
B. Column covers shall be fabricated in two vertically divided sections with attached provided through in indented installation fin.

Part 3 - Execution

3.01 Inspection & Installation

A. Contractor to inspect column covers upon receipt to ensure that no damage has occurred during shipment.
B. Column cover to be correctly oriented and installed in accordance with manufacturer's shop drawings and installation instructions to ensure proper installation.
C. Column cover to be erected plumb and level.

3.02 Cleaning & Protection

A. Contractor to remove protective material supplied by column cover manufacturer.
B. Contractor to clean all visible surfaces after installation.
C. Contractor to protect column covers from damage by other trades

Pittcon Industries Division Pittcon Custom Corporation

6409 Rhode Island Avenue
Riverdale, Maryland 20737
(800) 637-7638 , (301) 927-1000
Fax: (301) 699-8690

3330 W. Flower Street
Phoenix, Arizona 85043
(800) 637-7638 , (602) 233-9100
Fax: (602) 233-9400

© 2001 Pittcon Industries

Fabricated with Pride



Riverdale, Maryland-U.

Series 200 Details & Installation

